



Manufacturer of PCB Terminal Blocks, Fuse Holders, Barrier Terminals, & Switches

Screw Type (Cage-Clamp Design) Connectors

Series 90

[Model : 90/2, 90/3]

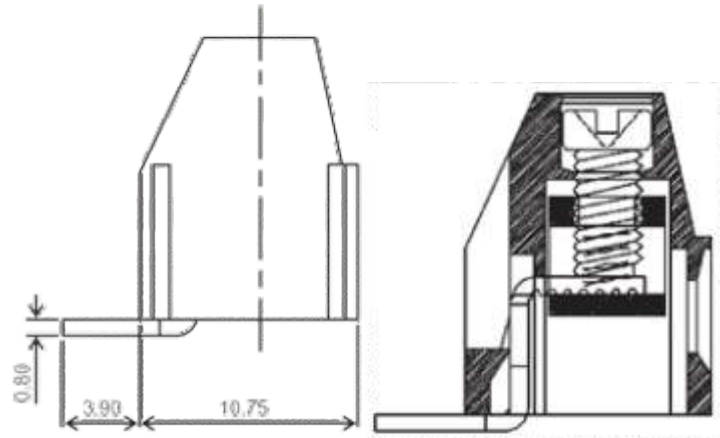
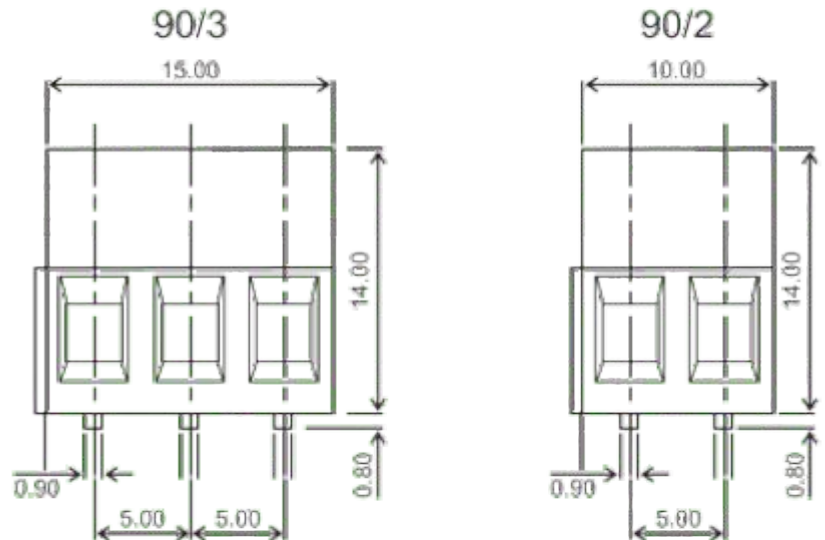

TECHNICAL SPECIFICATIONS :

Pitch	: 5.00 mm
Nominal Rating	: 15A/300V
Dielectric Strength	: > 2kV
Moulded Material	: PA66 - UL94 V0 or V2
Insulation Resistance	: > 1000 M Ω @ 500 Vdc
Terminal	: Tin Plated Copper Alloy
Wire Cage	: Nickel Plated Brass
Screw	: M3 x 0.50 mm : Brass Nickel Plated Suffix "P" : MS Trivalent Zinc Plated Suffix "C"
Wire Size	: 2.5 mm ²
Maximum Torque	: 0.30 - 0.40 Nm

Approval Data

UL : 300V / 12A / 26-14 AWG
cUL : 300V / 12A / 26-14 AWG
CE : 300V / 15A / 26-14 AWG

ORDERING CODE

Series	Poles	Grade
--------	-------	-------

→ 90/2 P ←

Number of Poles: 2 or 3
Grade : P or C

P = Professional Grade
C = Economy Grade